



## **RESIDENTIAL RE-ROOFING GUIDE**

(REVISED 9/30/16)

This guide provides general information for installing an asphalt roof on a residential structure.

### **PERMIT CHECKLIST:**

- ❑ Signed completed Building Permit Application or obtain permit online, state license is required for roofing contractors. **Permits are required for re-roofs.**

### **GENERAL BUILDING CODE REQUIREMENTS:**

- ❑ Existing roofing shall be torn off prior to installing the new roof where the existing roof has deteriorated to a point that the existing roof is not adequate as a base or there are two or more applications of any type of roof covering.
- ❑ Decking for asphalt shingles shall be solidly sheathed or 1 inch thick nominal wood boards. Damaged or deteriorated decking shall be replaced.
- ❑ Slopes for Asphalt shingles shall not be less than 2:12. (2 units vertical in 12 units horizontal)
- ❑ Underlayment shall be a minimum one layer of 15 pound felt, or equivalent meeting ASTM D 226, for slopes of 4:12 or greater and 2 layers for slopes of 2:12 up to 4:12.
- ❑ Ice and water protection shall comply with ASTM D 1970 and be provided at the eaves extending 24 inches inside the exterior wall line. Not required on detached unheated structures. Existing membrane may remain in place but must be covered with new.
- ❑ Asphalt shingles must be installed and fastened according to the manufacturer's instructions. Instructions are typically shown on each shingle bundle. Fasteners shall be galvanized or aluminum with minimum 3/8 inch diameter head and penetrate min. 3/4 inches into sheathing. Staples not allowed unless approved by manufacturer.
- ❑ Step flashing required at the junction of the roof/vertical surfaces, and roof penetrations installed per the roofing manufacturer's instructions.
- ❑ Valley flashing must be galvanized sheet gauge corrosion-resistant metal and shall be minimum 24 inches wide. Sections of flashing must be end lapped not less than four inches. Two plies of 36 inch roll roofing may be used or woven valley to code.
- ❑ Crickets/saddles shall be installed on ridge side of any chimney or penetration greater than 30 inches wide.
- ❑ Attic ventilation shall be installed at a minimum of 1 square foot per 150 square feet of attic space except that 1/300 is allowed provided that at least 50% and not more than 80% of the required ventilating area is provided by vents in the upper portion at least 3 feet above the eave/cornice vents with the balance of the required vents provided in the eave/cornice areas.

**REQUIRED INSPECTIONS:**

- ❑ **Final inspection:** When complete to verify proper venting, flashing and installation.

**GENERAL NOTES:**

- ❑ The Inspection Record card shall be visible from the street and shall remain posted until the final inspection has been made. Cards should be protected from the weather.
- ❑ Call (952) 985-4440 between 8:00 A.M. and 4:30 P.M. to schedule a final inspection. Provide at least 24-hour advance notice and provide permit number at time of scheduling. Access into the home is not required.

**Ice protection underlayment**

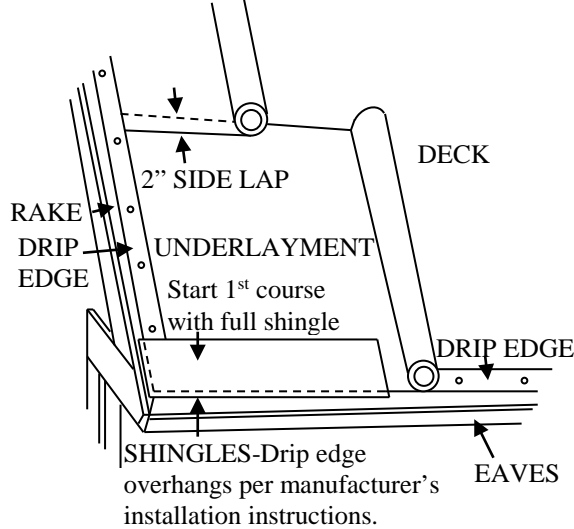

- When installing underlayment, care should be taken to install it wrinkle free. The underlayment should be installed over the eve drip edge and under the rake drip edge.
- Underlayment layers shall overlap 2 inches horizontally and 4 inches vertically.

**Shingle application using 5-inch method**

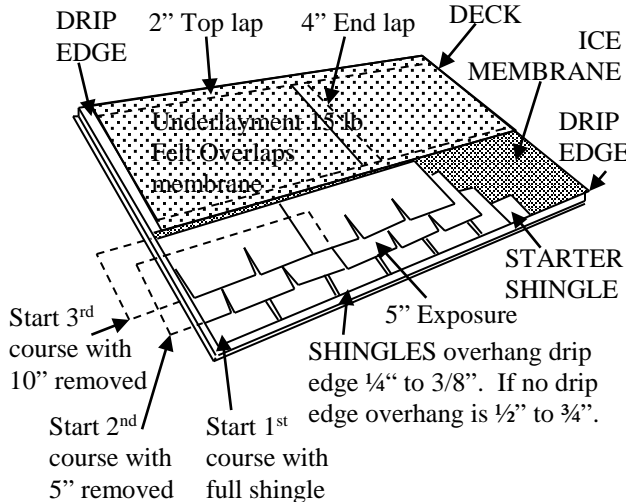

**Sidewall flashing (26 Gauge)**

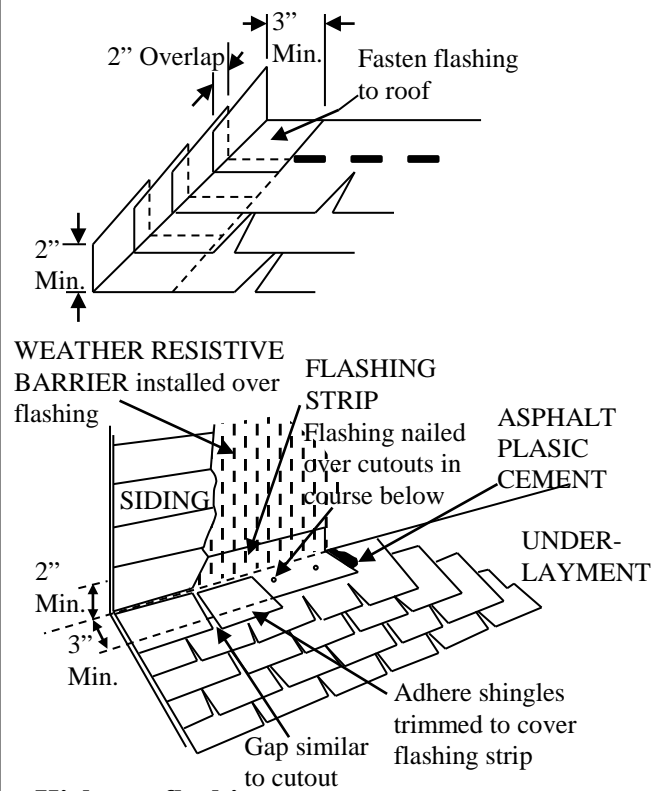

**Kick-out flashing**

